

9 8 7 6 5 4 3 2 1

These drawings and specifications are the exclusive property of Martin International Enclosures, Inc. and shall not be copied, reproduced or used for any purpose at all without prior written permission of Martin International Enclosures, Inc. (MIE) except to manufacture for MIE, Inc. the items on the drawings. These drawings are issued in strict confidence.

REVISION HISTORY			
REV	DESCRIPTION	DATE	APPROVED

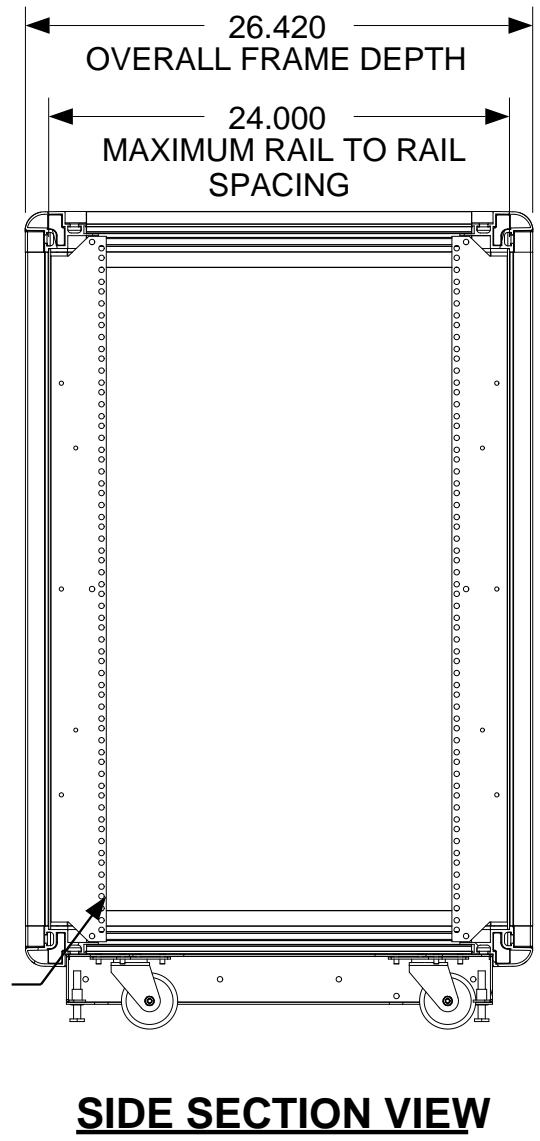
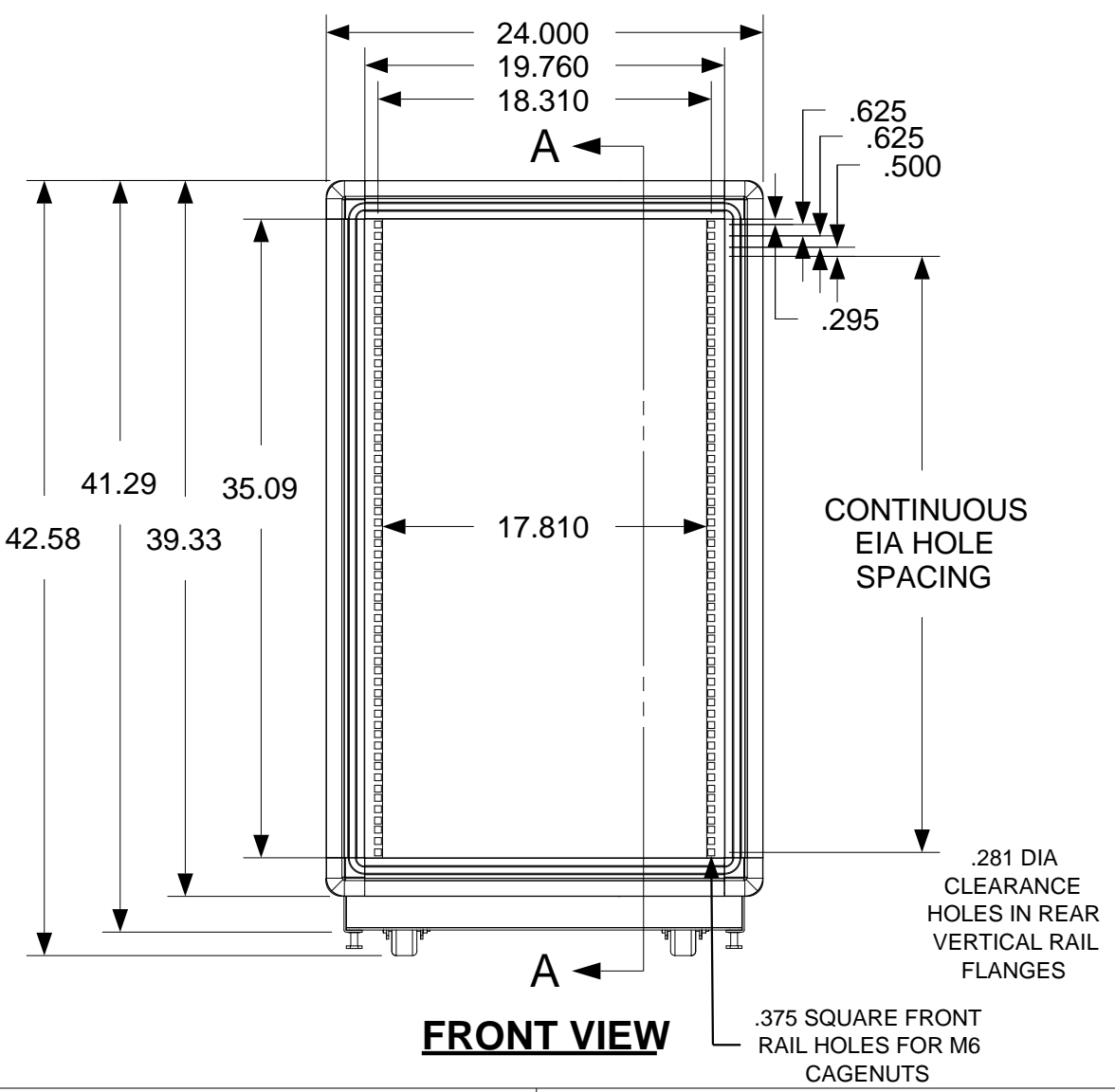
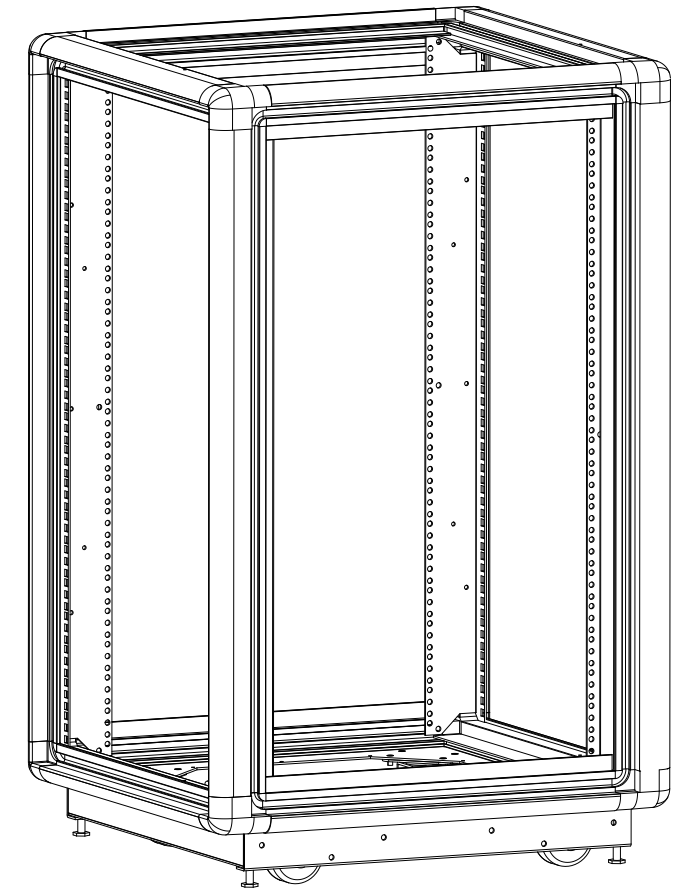
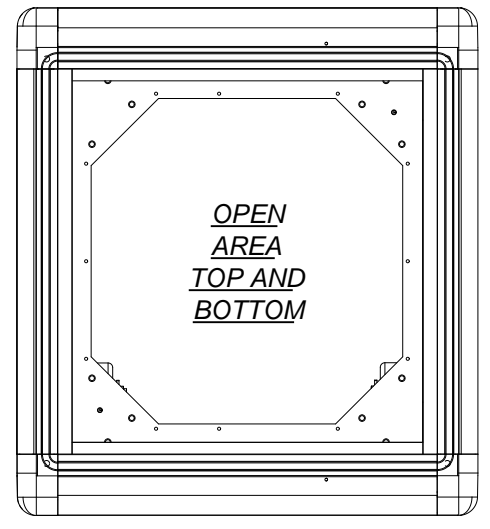

ITEM	PART NUMBER	DESCRIPTION	QTY
MATERIAL			<b>PART NAME</b> 20U X 24" DEEP; 19" RACKMOUNT EXTRUDED ALUMINUM FRAME
TOLERANCES EXCEPT AS NOTED DECIMAL .XX = +/- .020 .XXX = +/- .010 ANGULAR +/- 1/2 DEG			
DRAWN BY: SMM		SIZE B DATE 7/30/13 PART # 352024-L	REV
APPROVED BY:		FINISH: A/R	SHEET 1 OF 1

9 8 7 6 5 4 3 2 1